

CAUTION: PROTECT BALLS AND RACES FROM SAWDUST, DIRT, PAINT, ETC. SHOULD BEARING BECOME "ROUGH" FROM DIRTY RACES, FLUSH THOROUGHLY WITH HOT SOAPY WATER, RINSE, OVEN DRY AND RE-OIL.

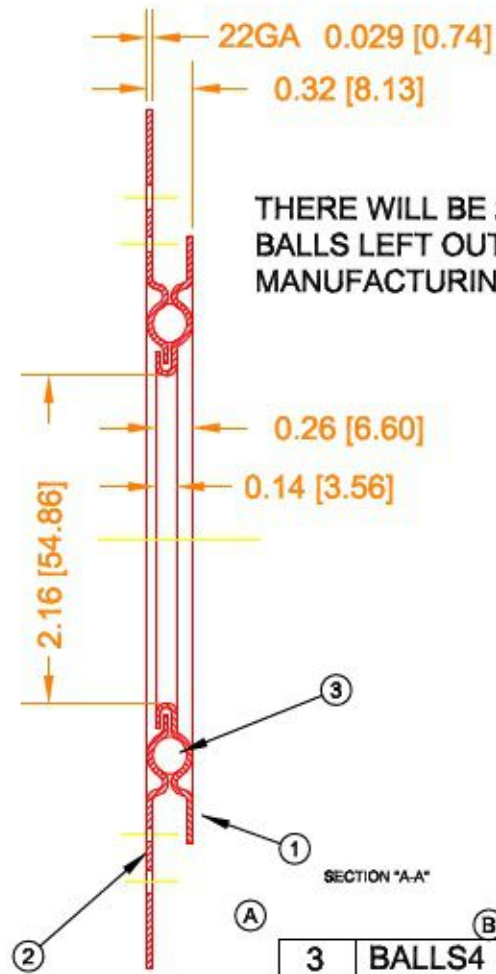
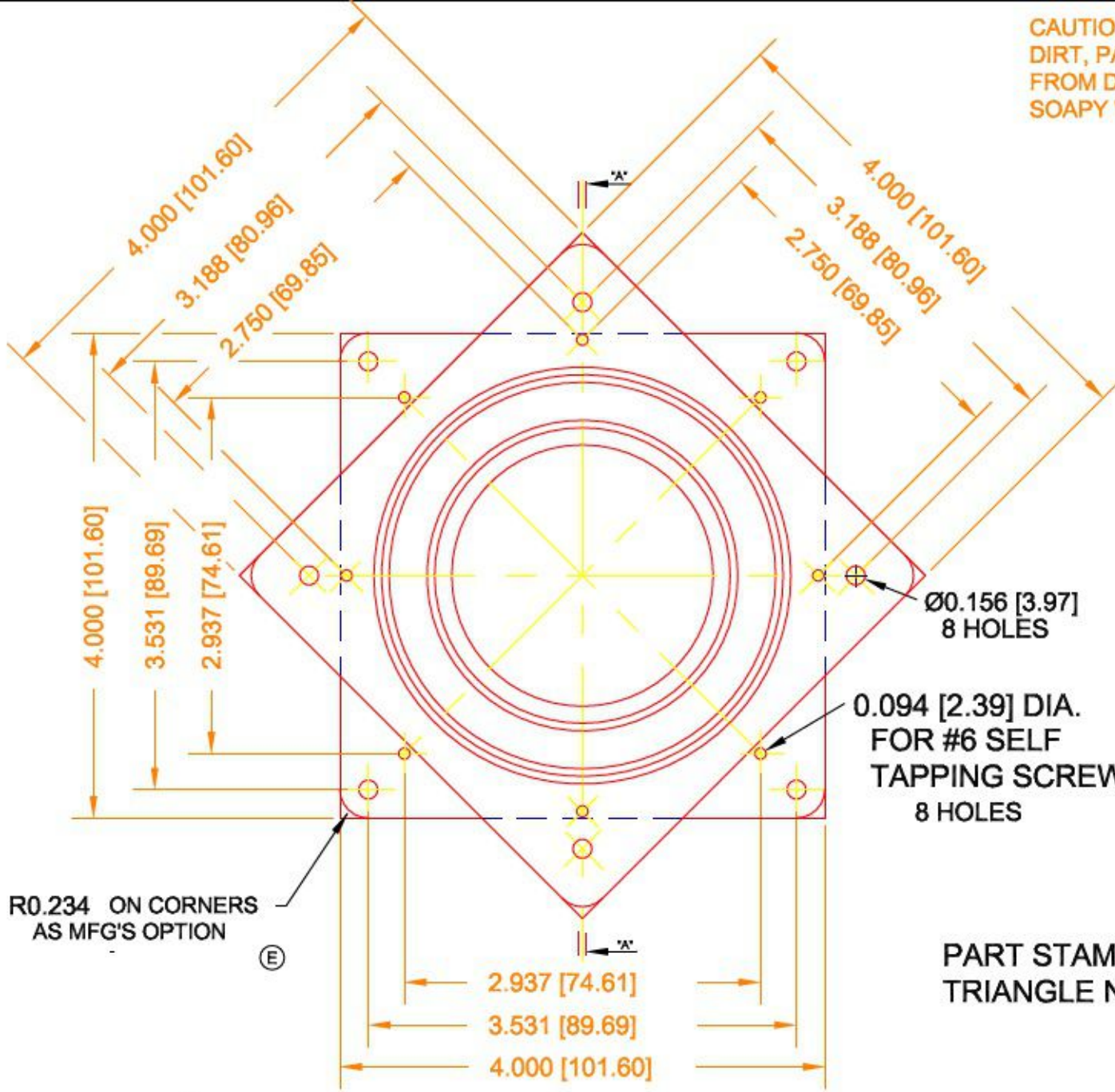

THERE WILL BE 2 TO 4 BALLS LEFT OUT DUE TO MANUFACTURING PROCESS.

PART STAMPED WITH TRIANGLE NAME STAMP

3	BALLS4	BALL	1
2	2823	PLAIN RACE	1
1	9486	STAMPING	1

DET	PART NUMBER	DESCRIPTION	AMT
-----	-------------	-------------	-----

**B** TRIANGLE MANUFACTURING CO.

NAME 4" LAZY SUSAN BEARING

USED IN 4C SERIES

DATE 11-25-59 PART NO.

SCALE 1 / 1

FIT	////
PLATING	ELECTRO-GALV
MATERIAL	SEE DETAILS
ALL DIMS ±.020 UNLESS SPECIFIED	

4C

CHANGE LEVEL	H	09-05-12
--------------	---	----------